

Important Safety Instructions:

****Instructions pertaining to a risk of fire, electrical shock, or injury to persons****

WARNING - When using this unit, basic precautions should always be followed, including the following:

1. READ AND FOLLOW ALL INSTRUCTIONS.
2. **DANGER:** To reduce the risk of injury, do not permit children to use this unit unless they are closely supervised at all times.
3. Use this unit only for its intended use as described in this manual. Do not use attachments not recommended by the manufacturer.
4. Never drop or insert any object into any opening.
5. Do not operate this unit without the guard over the suction fitting.
6. This unit must be connected only to a supply circuit that is protected by a ground fault circuit-interrupter (GFCI). Such a GFCI should be provided by the installer and should be tested on a routine basis. To test the GFCI, push the test button. The GFCI should interrupt power. Push the reset button. Power should be restored. If the GFCI fails to operate in this manner, the GFCI is defective. If the GFCI interrupts power to the bathtub without the test button being pushed, a ground current is flowing, indicating the possibility of an electric shock. Do not use this hydro massage bathtub. Disconnect the hydro massage bathtub and have the problem corrected by a qualified service representative before using.
7. SAVE THESE INSTRUCTIONS.



Grimm Scientific Industries, Inc.
P.O. Box 2143, Marietta, OH 45750
www.grimmscientific.com

Tel: 800-223-5395
Fax: 740-374-5745
e-mail: joe@grimmscientific.com

Important Safeguards:

The following safety precautions should always be followed when using CRYOTherm.

1. Use CRYOTherm only as directed in this manual. Improper use can cause injury.
2. Do not plug CRYOTherm into any electrical outlet that is not protected by a ground fault interrupter and matches the voltage and amperage specification.
3. Do not modify the power cord in any way or use with any type extension cord.
4. Do not permit any electrical appliance such as television, radios, lamps, clocks, fans, etc. within 5 feet of the tank water, doing so creates the risk of electrical shock.
5. Maintain CRYOTherm as described in this manual. Improper maintenance can cause injury.
6. Do not modify CRYOTherm in any way or attach additional appliances to the frame without consultation with the Grimm Scientific factory.
7. Do not use CRYOTherm if any broken or non-functional components are found, doing so may result in additional damage.
8. Use only Grimm-approved parts and service, improper parts or service can cause harm to the system and/or users.
9. To prevent the transmission of pathogens, people with infectious diseases or open wounds should not use the CRYOTherm.
10. Thoroughly clean the tanks with a disinfectant at least once a week. Refer to the [care and maintenance](#) section for further safeguards and instructions for cleaning CRYOTherm, use of an antibacterial agent when filling the tanks helps prevent or reduce infection.
11. Do not utilize warm or hot water treatment where there is hemorrhaging or swelling.
12. Patients with any medical contraindications to cryotherapy, thermotherapy, or hydrotherapy should not use CRYOTherm. Some conditions may include but are not limited to; obesity, heart disease, low or high BP, circulatory problems, diabetes, sickle cell anemia.
13. Prolonged immersion in the tubs may cause harm.
 - *Be aware that patients may develop heat stress syndrome when CRYOTherm is used at high temperatures for prolonged periods.*
 - *Be aware that patients may develop hypothermia when CRYOTherm is used at low temperatures for prolonged periods.*
14. Never allow patients to use drugs or alcohol before using CRYOTherm, doing so increases the risk of hypothermia, hyperthermia, loss of consciousness, and drowning.
15. Pregnant or possibly pregnant women should consult their physician before using CRYOTherm.

Important Safeguards (continued):

16. Advise patients to refrain from adjusting controls, and never leave patients alone.
17. Thoroughly clean the tanks with a disinfectant at least once a week and particularly after treating open lesions (see "Maintenance" section of this manual).

Water Temperature Terminology:

Very Cold	40° F to 55°F	5° C to 13° C
Cold	55° F to 60°F	13° C to 16° C
Warm	90° F to 98°F	32° C to 37° C
Hot	98° F to 104°F	37° C to 40° C

Control Functions:

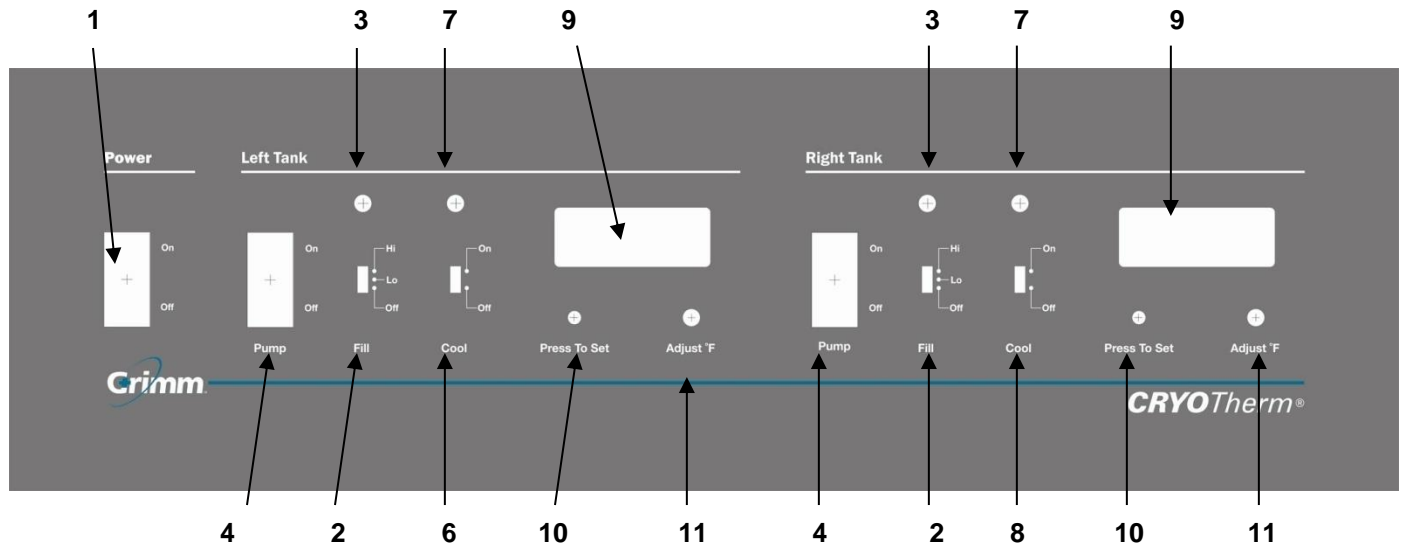

1. **Power Switch** - Activates all electrical components.
2. **Fill Switches** - Activate automatic water level controls.
3. **Fill LEDs** - Indicate when tank is filling.
4. **Pump Switches** - Activate dual speed circulation pumps.
5. **High Speed Button** - Switches pump speed from low to high for 20 minutes.
6. **Left Cool Switch** - Activates cooling temperature control for left tank.
7. **Cool LEDs** - Indicate temperature controls are cooling.
8. **Right Cool Switch** - Activates cooling temperature control for right tank. This switch must be off to activate heating control.
9. **Digital Displays** - Display water temperature and temperature control settings.
10. **Press-To-Set Button** - Switches digital display from reading the actual water temperature to reading the temperature control setting.
11. **Adjust Slot** - Adjusts (use small screwdriver supplied) temperature control settings when Press-To-Set button is pressed.

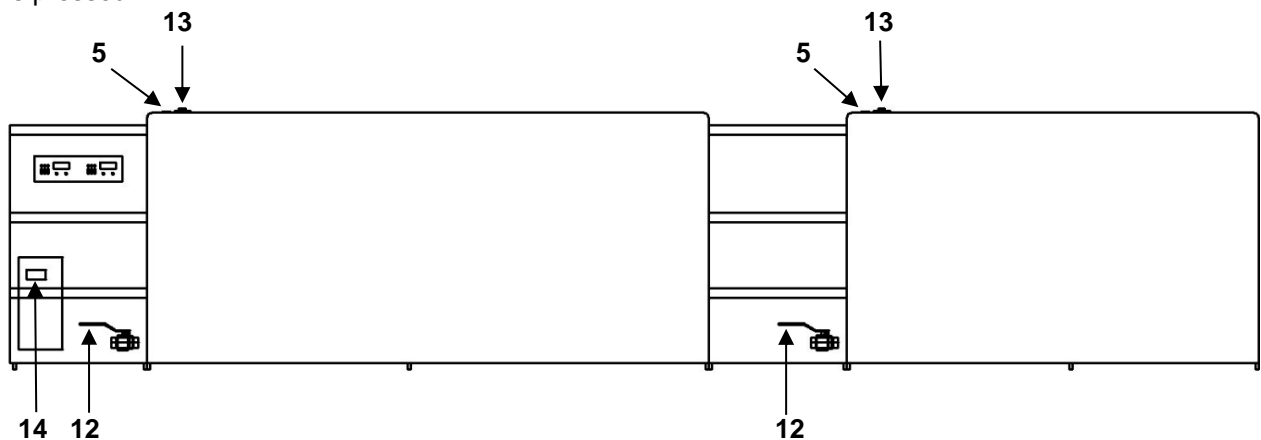

12. **Drain Valves** - Manually drain tanks. Power switch should be switched off.
13. **Air Controls** - Controls air supply to hydrotherapy jets while pumps are running.
14. **Reset** - Resets system following loss of cold water supply pressure.

Installation:

WARNING – When using electrical products, basic precautions should always be followed, including the following:

- **DANGER: RISK OF ELECTRIC SHOCK.** Connect only to a circuit protected by a ground-fault circuit-interrupter.

Grounding is required. The unit should be installed by a qualified service representative and grounded

1. Electrical Connection

Power requirements for the Model 4977 CRYOTherm are 208 Volts, Single-Phase 4-Wire, 60 hertz, 38 amps.

Plug the CRYOTherm only into a voltage-matched NEMA 14-50R outlet that is properly ground, polarized, and protected with a 50 Amp ground-fault-circuit-interrupter (GFCI) circuit Breaker.

Use professional electrical assistance and follow the National Electrical and local codes as a minimum.

2. Site Preparation

The attached Spec Sheet indicates the utilities necessary for installation of the CRYOTherm. Consideration should also be made for the 11,087-pound load this unit will place on the floor and building structure.

3. Level CRYOTherm

Stainless steel hex head leveling feet are provided to give uniform support. Thread these into the frame before positioning the unit. Place a level on the top Corian surface and level the CRYOTherm.

4. Drain Connections

A 1-1/2-inch copper drain connection is provided. This should be positioned over an open, trapped floor drain with an adequate air gap. Refer to local plumbing codes for specific requirements.

5. Cold Water Supply Connection

A 3/4" NPT connection is provided for connection to the cold-water supply. An internal dual check valve protects the supply. This supply fills the tanks and uses an average of .04 gallons per minute to control the warm tank temperature.

When the supply pressure fails, the high-pressure cutout on the refrigeration system will trip, making it necessary to press the reset (see #14 under control functions) after the pressure is restored.

****See Important Safety Instructions****

Operating Instructions:

The causes, symptoms, and effects of hyperthermia may be described as follows:

Hyperthermia occurs when the internal temperature of the body reaches a level several degrees above the normal body temperature of 98.6°F. The symptoms of hyperthermia include an increase in the internal temperature of the body, dizziness, lethargy, drowsiness, and fainting. The effects of hyperthermia include:

- a) Failure to perceive heat;
- b) Failure to recognize the need to exit the hydro massage bathtub;
- c) Unawareness of impending hazard;
- d) Fetal damage in pregnant women;
- e) Physical inability to exit the hydro massage bathtub; and
- f) Unconsciousness resulting in the danger of drowning

WARNING - The use of alcohol, drugs, or medication can greatly increase the risk of fatal hyperthermia.

Operation:

Operators should have a working knowledge of clinical hydrotherapy and cryotherapy procedures. In addition, each operator should thoroughly read and understand the procedures in this manual before treating patients with CRYOTherm.

1. Fill Tanks

Both tanks must be filled for proper operation of CRYOTherm. To fill the tanks first, make sure all control panel switches are in the off position and the drain valves are closed. Press the power switch to on and then slide the fill switches to the "Hi" or "Lo" level and allow the water level to rise. Automatic level switches located behind the overflow grille will control water levels at "Lo" = 4" and "Hi" = 2" to the top of the tank.

Note: *These level controls have a ten-second delay to avoid valve chatter.*

Helpful Hint: *During contrast treatments level switches, can be turned off to avoid loss of temperature due to tanks being constantly filled with water to replace that discharged from the overflow.*

2. Water Supply Requirements

CRYOTherm requires connection to a constant water source in order maintain water level and to allow the refrigeration system to work properly. If water supply is lost the electronic unit controller will shut down the refrigeration system and will require reset to restore function. (see Control Function #14 and the troubleshooting section).

3. Switch Pumps "On"

When the water level covers all jets the pump switches (see Control Function #4) may be switched "on" to begin circulating the water.

WARNING: *Do not run the pumps when the tanks are empty.*

With the dual speed pumps switched on water will circulate through the hydrotherapy jets at low speed. The pumps may be switched to high speed by depressing the white button (see Control Function #5). After 20 minutes the pump will automatically resume low speed operation. The air control valve next to the pump speed button can be turned to adjust the amount of aeration during treatment (see Control Function #13).

Important: *The pumps must be left on at all times for proper operation. Reliable aeration only occurs at high speed.*

4. Select Tank Temperatures

To set the temperature of each tank press and hold the corresponding Press-To-Set button (see Control Function #10), when depressed the digital display will switch from reading the actual tank temperature to indicating the set point temperature. Insert the small screwdriver that was supplied into the slot adjacent (see Control Function #11) and adjust the set point of each tank to the desired temperature. When the button is released, the digital display will return to reading the actual tank temperature.

Left Tank -The left tank is a dedicated cold tank adjustable from 40°F to 70°F. Heat removed from this tank is used to heat the right tank. Slide the Left Cool switch to "On" and the CRYOTherm will seek the set point temperature and control at that point. Cooling rate is approximately four degrees per hour.

Right Tank - The right tank can be operated at either warm or cold temperatures. With the Right Cool switch switched "Off" the water temperature can be set to any warm temperature up to 110°F. With the Cool switch switched "On" cold temperatures as low as 40°F may be selected.

Operation (continued):

5. Patient Loading & Unloading

Users may access the tanks via the compartment steps or over the front and side edges around the perimeter of the tank. Users also have access to the pump speed button and air control dial during the course of treatment however they should never touch the control panel settings beneath the clear plastic cover. CRYOTherm is designed to accommodate all size athletes and support them either standing, seated, or kneeling in the tank or sitting anywhere on the exterior Corian surface.

When exiting CRYOTherm via the compartment steps, care should be taken not to splash excessive water onto the surface of the steps or around the control panel. The clear plastic cover should remain in place whenever CRYOTherm is in use, to avoid splashing of the controls and accidental moving of the switches.

Important Note:

Water level controls prevent overflow during filling and operation of CRYOTherm, however, patient loading can result in overflow of the tank if entry into the tank is too rapid. Athletes should be instructed to enter the tank slowly, allowing the overflow drain to accommodate the displaced water and prevent overflow of water onto the floor and electrical components.

When exiting CRYOTherm via the compartment steps, care should be taken not to splash excessive water onto the surface of the steps or around the control panel. The clear plastic cover should remain in place whenever CRYOTherm is in use, to avoid splashing of the controls and accidental moving of the switches.

Tripping of the GFCI breaker is possible if a CRYOTherm tank is overflowed, or excessive water is splashed in the area of electrical components. If this occurs the area should be allowed to dry out, and the breaker reset to restore normal operation.

Care & Maintenance:

CRYOTherm is constructed of the highest quality and most durable materials of any hydrotherapy device on the market. Proper care and maintenance of your CRYOTherm will extend the life of its components and provide safe and sanitary environment for your athletes.

1. The entire CRYOTherm should be completely drained, inspected, cleaned, and disinfected at least once a week.
2. CRYOTherm has seamless stainless-steel tanks with coved corners which are easily wiped down and don't harbor bacteria. Stains in the tank that do not wipe away easily may be removed using cleaner and a **Maroon Pad**. Apply light to moderate pressure in the direction of the grain of the steel. Never use stainless steel cleaner to clean the tanks.
3. The solid surface Corian exterior surface of CRYOTherm is also seamless, non-porous, and stain resistant. Any stubborn marks that do not easily wipe away can be buffed with a wet **Maroon Pad**, apply light to moderate pressure in a circular pattern.
4. Filter cartridges should be cleaned frequently and replaced regularly to assure they remain effective in removing potentially harmful particles from the system that can damage CRYOTherm components. Consistent use of an **enzyme cleaner** will extend filter life and other hydrotherapy components by enhancing the cleanliness of the piping system.
5. Routine culturing of the tanks should be done. Culturing kits are available from Grimm Scientific. Further guidelines for culturing can be obtained through clinical laboratory or hospital infection control departments.
6. Consult your Grimm representative with questions or problems.

Care & Maintenance (continued):

Weekly Cleaning Procedure

1. Move all switches on the control panel to the “off” position.
2. Open the drain valve(s) to drain the tanks.
3. When tanks are empty remove the filter cartridge(s). See the Changing the Filter Cartridge section of this manual for further instructions.
4. Remove any debris from around the pump suction, drain covers, filter housing, and hydrotherapy jets.
5. Use **pure disinfectant spray** (or comparable product) to clean all exposed surfaces of the tank, the Corian exterior, and the inside of the filter housing. Allow disinfectant to stand on the surfaces for at least 30 seconds before wiping. **Note: longer contact times may be required for certain pathogens, refer to product label for specific instructions.**
6. Examine tank walls, exterior surfaces, and associated components for damage and visual cleanliness. Remove any stains using the techniques described in the Care and Maintenance section of this manual. Report any damage to your Grimm representative.
7. Install a clean filter cartridge(s), refer to the Changing the Filter Cartridge section of this manual.
8. Close drain valves.
9. Fill tanks according to procedure described in the Set Up and Operation section of this manual.
10. Refer to the Water Balance section of this manual for information and advice about keeping water clean and sanitized.

Care & Maintenance (continued):

Changing the Filter Cartridge(s)

CRYOTherm is equipped with easily accessible top load filters for quick and convenient cartridge replacement. Replacement cartridges can be purchased from Grimm via our website or phone contact.

1. With the pumps off and the tanks drained, lift the gray tab on the lock ring assembly and turn the ring in a counterclockwise direction to loosen and remove the ring.
2. With the ring removed, grasp the handle on the filter lid and lift, removing the lid from the filter housing.
3. Lift and remove the filter cartridge and clean away any debris remaining inside the filter housing.
4. To clean and disinfect the filter housing, spray the inside surface of the housing and lid with **pure disinfectant spray** (or comparable product) and allow surfaces to remain wet for at least 30 seconds before wiping and reassembling filter.
5. A bromine feeder is included in the filter assembly. Should you choose to use bromine review the Water Quality Fundamentals on pages 13 thru 16 in this manual.

Load Tablets



Adjust Flow



6. To reassemble, insert a new or cleaned filter cartridge into the housing and replace the lid. Push the lid down completely to assure that it is fully inserted into the housing.

Important: the *rubber o-ring on the lid should be routinely inspected to evaluate wear and need for replacement.*

7. Reinstall the locking ring and turn in a clockwise direction to tighten ring. Do not over tighten.
8. The cartridge that was removed should be discarded or cleaned for future use.
9. Proper cleaning of the cartridge includes soaking in filter cleaner, rinsing thoroughly, allowing to dry, and storing in a dry location for future use.

Water Quality Fundamentals (continued):

Water Testing

The factors that determine water balance are easily measured using test strips that are dipped into the water and then compared to color coded scales to evaluate levels. Characteristics of the source water, amount of use, cleanliness of users, cleaning schedule, temperature of water, and other factors can affect water balance. The most important parameter for CRYOTherm users to monitor and adjust is pH. Signs that you may have a pH or other water balance problem are as follows:

Signs of high pH, total alkalinity, and/or calcium hardness

- Cloudy water
- Accumulation of scale
- Reduced circulation from clogged filters, heaters, or piping
- Eye/skin irritation

Signs of low pH, total alkalinity, and/or calcium hardness

- Etching or staining of surfaces
- Corrosion
- Foaming water
- Eye/skin irritation

Test kits are also available to evaluate the amount of various mineral and metal contaminants in the source water. Your local pool store may also provide this service for you. Based on findings, the water can be treated to remove the damaging materials.

If the decision is made to treat the water with a disinfectant (chlorine or bromine), it will be important to test the water to evaluate the levels of residual disinfectant to make sure it is effectively sanitizing the water without causing irritation of the skin or eyes of the users. Test strips are the easiest way to test for the disinfectant levels in the water. It is important to strictly follow manufacturer's instructions when testing the water and when adding chemicals to the water. Ideal ranges are as follows:

- | | | | |
|---|------------|----------------------|--|
| - | <i>FC</i> | <i>Free Chlorine</i> | <i>2 to 4 ppm ideal range, 1 to 4 ppm acceptable range</i> |
| - | <i>TBr</i> | <i>Total Bromine</i> | <i>3 to 5 ppm ideal range</i> |

Water Quality Fundamentals (continued):

Water Treatment

The first step to any chemical treatment of water is to determine if any change in water chemistry is necessary. Because CRYOTherm's water is continuously refreshed with normal use and completely replaced at least weekly by the user, you may find that chemical treatment of the water is not warranted. If routine testing shows values that are not within acceptable ranges, chemical adjustment may be needed.

We have found that pH is the most important factor. When pH is in ideal range, all other factors tend to fall in line. If you are having trouble maintaining an ideal pH, you may first need to adjust Total Alkalinity which serves as a buffer to resist changes to pH levels.

Follow these guidelines after filling the CRYOTherm:

- If there is a known water source problem the water should be treated first pursuant to an established protocol to remove the potentially harmful contaminants.
 - o Your Grimm representative can assist you with establishing proper protocol.
- If Total Alkalinity (TA) is not in ideal range adjust it first.
 - o **SpaPure Alkalinity Increaser**
- Adjust pH once TA is within ideal range and stabilized
 - o High pH – adjust with **SpaPure pH Down**
 - o Low pH – adjust with **SpaPure pH Up**
- If using a sanitizer, add sanitizer only after TA and pH are within ideal ranges and stable, this will assure it works most effectively and reduce the amount you need to use.
- Treat water with **ORB-3 Spa Enzyme No Foam** approximately 30 minutes after introducing sanitizer.

NOTE: When using chemicals always read the labels and strictly follow the manufacturer's instructions regarding dosage, handling, storage, and disposal. All of the products needed to comply with these recommendations can be purchased directly from Grimm Scientific.

Sanitizers

Sanitizers that are part of the chemical family known as halogens are the most utilized method of water disinfection. These products kill microorganisms, including bacteria, by attacking their cell walls through oxidation. They destroy the enzymes and structures inside these cells, which renders them harmless. Chlorine and Bromine are the most widely used sanitizers and come in various forms.

- Chlorine is probably the most recognized water treatment. Typically added to water in a granular form, it is an effective sanitizer for all applications. It is important to maintain chlorine concentration to within acceptable ranges.
- Bromine is another effective sanitizer; it is preferred by some because it is less likely to produce odors and skin irritation. Bromine is considered the best sanitizer for warm water applications since it does not dissipate rapidly. Using bromine tablets in a floating dispenser is a simple and effective way

Factors to consider when choosing the best disinfectant to use in your CRYOTherm and the best method of application are:

- Water temperature
- Usage load
- Source water chemistry
- Chemical storage and safety concerns
- Supervision and maintenance concerns

Water Quality Fundamentals (continued):

Water Testing and Treatment Checklist

Note: ALWAYS carefully read and strictly follow all manufacturer's instructions and recommendations when storing, handling, and adding any chemical product to your CRYOTherm water.

1. After each scheduled weekly cleaning fill tank(s) with water as described in the **Set Up and Operation** section.
2. With pump(s) turned off, use a test strip according to manufacturer's instructions to evaluate the **Total Alkalinity (TA)** and **pH** of the water.
3. If **pH** is out of range (**7.2 – 7.8**) adjust it using **SpaPure pH Up** or **pH Down**.
If **TA** is out of range adjust it first using **SpaPure Alkalinity Increaser**.
4. If using a sanitizer add it now and turn the pump(s) on.
SpaPure Bromine Tablets in feeder

Note: Floating dispensers should be removed while the tank is in use

5. 30 minutes after introducing the sanitizer, treat the water with the appropriate amount of **ORB-3 Spa Enzyme No Foam**
6. Recheck **pH** and **sanitizer** levels periodically throughout the week to assure the water is staying in range and adjust as necessary. After a few weeks, you will establish a workable routine.
7. If, after 3-4 days of operation, the water shows signs of imbalance, treat water with **SpaPure Oxidizing Shock** and add additional **ORB-3 Spa Enzyme No Foam**. **

Note: If shock and enzyme product does not bring the water into balance consider draining and cleaning the tank.

8. Contact your Grimm consultant with questions, problems or any specialized needs.

Service:

1. Trouble Shooting

Problem	Possible Cause
<ul style="list-style-type: none"> Nothing happens when Power switch is switched "On". 	<ul style="list-style-type: none"> Power cord unplugged. GFCI breaker tripped.
<ul style="list-style-type: none"> CRYOTherm won't cool or heat. 	<ul style="list-style-type: none"> Check that the water supply is on, then press and hold (for 3 seconds) the start button on the Electronic Unit Controller shown below. Check that both pumps are on and pumping water.
<ul style="list-style-type: none"> Water Cloudy 	<ul style="list-style-type: none"> Check filter cartridges.
<ul style="list-style-type: none"> Water circulation impaired. 	<ul style="list-style-type: none"> Check pump suction fittings for debris. Check filter cartridges.
<ul style="list-style-type: none"> Warm tank not holding temperature 	<ul style="list-style-type: none"> Check heater reset button

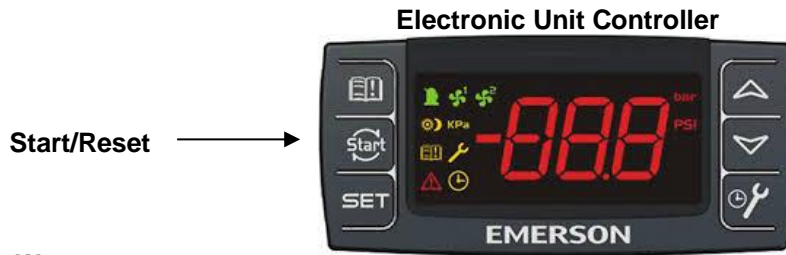

2. One Year Warranty

The CRYOTherm warranty applies to purchaser and any subsequent owner. Grimm Scientific Industries, Inc. (warrantor) warrants this product to be free from defects in material and workmanship under normal use for one year from the date the product is shipped. The warrantor may opt to replace the product, rather than repair it. This warranty does not cover damage resulting from accidents, improper use, or maintenance of this product, and in no case, shall warrantor's liability exceed the original purchase price paid for the product. This warranty is expressly in lieu of all other express warranties.

3. Repairs

Should repairs be needed on your CRYOTherm, simply call the factory and ask to speak with a service technician. We will repair it free during the first year and quote/invoice a reasonable charge for parts and labor provided after the warranty expires.

4. Inspection & Calibration

Every year a qualified service technician should check the CRYOTherm. Temperature control calibration should be verified with a certified thermometer and electrical system tested for grounding and leakage current. Grimm can provide this service.

5. Call 1-800-223-5395

All Grimm products are sold and serviced directly by the factory. Call us toll-free Monday through Friday, 8:00 a.m. to 5:00 p.m. EDT about your thermal therapy needs. We are often available before and after hours so call us anytime.